

HAUG Ionization - for the elimination of electrostatic charges



Ion-Air one

The **Ion-Air one** low-pressure blower is a versatile device for the elimination of electrostatic charges on non-conductive material.

An airflow, enriched with either positive or negative ions, neutralizes interfering surface charges and removes – depending on the working distance – debris from the surface. The **Ion-Air one** does not need compressed air. Room air is drawn in, filtered, accelerated by the fan, and then simultaneously ionized and blown out again.

The speed control of the **Ion-Air one** is progressively adjustable. In order to guarantee the constant efficiency of the **Ion-Air one**, the air filter must be replaced regularly.

The integrated clogged filter LED indicator illuminates when the filter is clogged.

Although primarily designed to serve as table-top unit, the **Ion-Air one** can be used as series device for electrostatic discharge mounted with appropriate fixation elements above material sheets and webs.



IR 1

Applications

The **Ion-Air one** proves to be very efficient in a wide range of applications such as

- wind up material webs (especially on film and foil winders);
- at the discharge point of injection moulding machines for plastic materials;
- in the electronic industry and assembly work places.

ill. 1

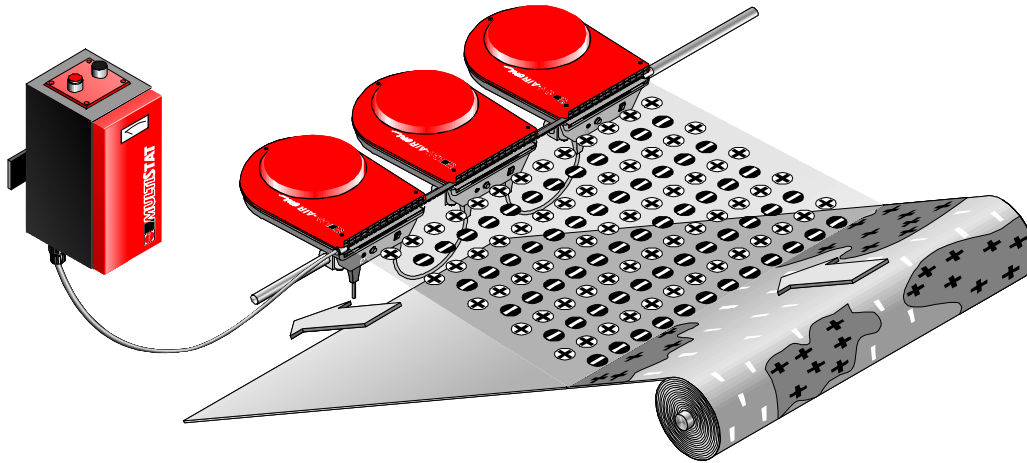

Ion-Air one

Equipment of the table-top unit

The table-top unit is available ready for use and contains the following components:

- an integrated power-pack to supply the built-in ionizing bar;
- an integral heating element, which can be switched on when required, to raise the temperature of the exhaust air flow to a level comfortable for the operator (ill. 3);
- a plate-shaped base to ensure the steadiness of the device and to optimize the angle of the exhaust air flow according to the application requirements.

ill. 2

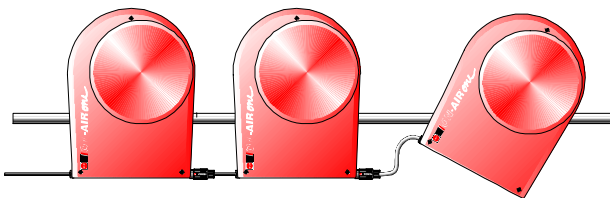

ill. 3

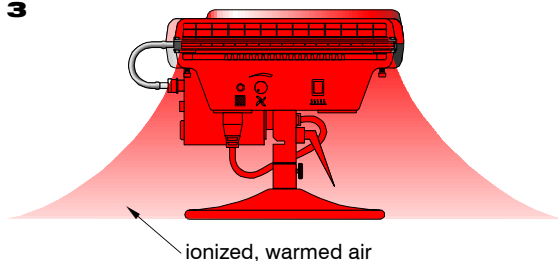

Equipment of the series unit

The series unit is mounted on a transversal bar above a material web. For the series unit, an appropriate ionizing bar and suitable power pack (e.g. with monitoring) must be ordered separately according to the application requirements.

The following configurations are possible:

- Any high-voltage power pack, out of the complete range of HAUG power packs, combined with one ionizing bar mounted over the total length of all connected **Ion-Air one** units (ill.1).
- One high-voltage power pack, as above, combined with several ionizing bars which are interconnected with a high-voltage cable (ill.2).

The versatile and elaborate mounting accessories, which must be ordered separately, suit any possible mounting situation.

HAUG GmbH & Co. KG

Germany

Friedrich-List-Str. 18
D-70771 Leinf.-Echterdingen
Phone: +49 711 / 94 98-0
Telefax: +49 711 / 94 98-298

www.haug.de
E-mail: info@haug.de

HAUG Biel AG

Switzerland

Johann-Renfer-Str. 60
CH-2500 Biel-Bienne 6
Phone: +41 32 / 344 96 96
Telefax: +41 32 / 344 96 97

www.haug-ionisation.com
E-mail: info@haug-biel.ch

Air Line - Ion-Air one IR 1





Pivoting bracket for mounting on the transversal bar

Order-No.: 10.0024.000

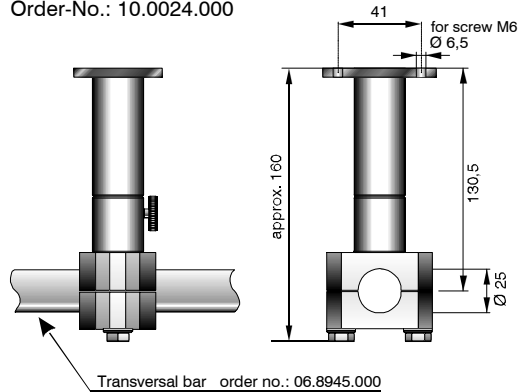

Support for mounting the transversal bar on the machine

Order-No.: X-2401

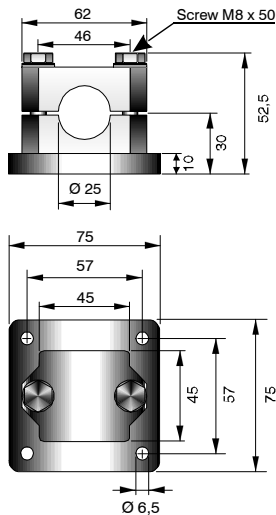
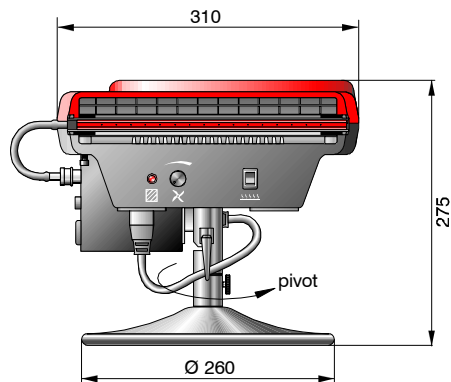

Table top unit



Ion-Air one

Technical data Ion-Air one IR 1

Types: **IR 1** (230 V) table-top unit Order-No.: 04.0311.000
IR 1 (115 V) table-top unit Order-No.: 04.0310.000
 incl. clogged filter indicator, switchable heating element, EN CL power pack, EI PRQ ionizing bar, plate-shaped base.

IR 1 (230 V) series unit Order-No.: 04.0309.000
IR 1 (115 V) series unit Order-No.: 04.0308.000
 incl. clogged filter indicator, pivoting bracket, mains cable. Please order ionizing bar and power pack separately!

Protection type: IP 20
 Protection class: II
 Supply voltage: 115 V_ / 230 V_ (50 – 60 Hz)
 Power consumption: approx. 500 VA (table-top unit)
 approx. 100 VA (series unit)

Weight: 12 kg (table-top unit)
 7 kg (series unit)

Operating temperature: +5 °C to +45 °C

Storage/transport temperature: -15 °C to +60 °C

Subject to technical changes!

Accessories

Spare filter: Order-No.: X-2396
 Pivoting bracket for mounting the IR 1 on the transversal bar: Order-No.: 10.0024.000
 Transversal bar Ø 25 mm: Order-No.: 06.8945.000
 Support for mounting the transversal bar on the machine: Order-No.: X-2401
 Connection cable: Length 150 cm Order-No.: 06.8940.793

